

---

---

---

---

DESOLDERING TOOL

**HAKKO ACE** No. **483**

INSTRUCTION MANUAL

---

---

---

---

Please read this instruction manual thoroughly before  
operating the HAKKO ACE No.483 unit.

---

Developed from years of soldering experiences, the HAKKO ACE No.483 is a newly designed desoldering tool featuring the latest advance in soldering technology. This instruction manual describes the correct methods of operation, inspection and repair.

---- Table of Contents ----

	Page
1. Specifications .....	1
2. Part Name .....	3
3. Setting Up No.483 .....	5
4. Operating Procedures .....	5
5. Maintenance .....	8
6. Troubleshooting Guide .....	17
7. Wiring Diagram .....	18
8. Replacement Parts .....	19

The specifications written here may be subject to change without notice.

## 1. Specifications

### Electrical Rating

Electric Supply AC 110-120V, 220V-230V,  
240V.

Input Power 95 W

### a) Desoldering Station (Vacuum Pump)

Pump Type Diaphragm Type

Pressure 600 *mm* Hg (Maximum)

Motor Output Power 25 W (4 - Pole)

Fuse Power 2 A

Outer Dimensions 150 *mm* (5.9 in) (W) × 130 *mm*  
(5.12 in) (H) × 200 *mm* (7.87 in) (D)

Weight Approx. 3.4Kg (7.48 lb)

### b) Desoldering Iron

Heating Element 45 Watts (Ceramic)

Temp. Control 300°C (572°F) - 400°C  
(752°F) continuously  
variable.

Filter Pipe Pyrex (heat resist glass)

Filter 2 stage (easy replaceable)

Cord / Hose 1.5 meters (59.06 in) each

Pump Connection Large metal connector  
plug (with grounding pin)

Nozzle Inner Dia. Standard 1.0 (0.039 in) *mm*,  
0.8 *mm* (0.031 in), 1.3 *mm* (0.051 in)  
& 1.6 *mm* (0.064 in) are optional

Weight Approx. 230g (0.51 lb) w/o  
Cord & Hose.

c) Accessories

*Special Iron Stand	1 pc.
*Nozzle Cleaning Wrench	1 pc.
*Large Cleaning Pin (for Heating Core)	1 pc.
*Small Cleaning Pin (for Nozzle & Heating Core)	1 pc.
*Steel Wool Filter	5 Pcs.
*White Felt Filter	5 Pcs.
*Anti seizing Labricant	1 pc.
*Check Valve	1 pc.

## 2. Part Name

### a) Vacuum Pump

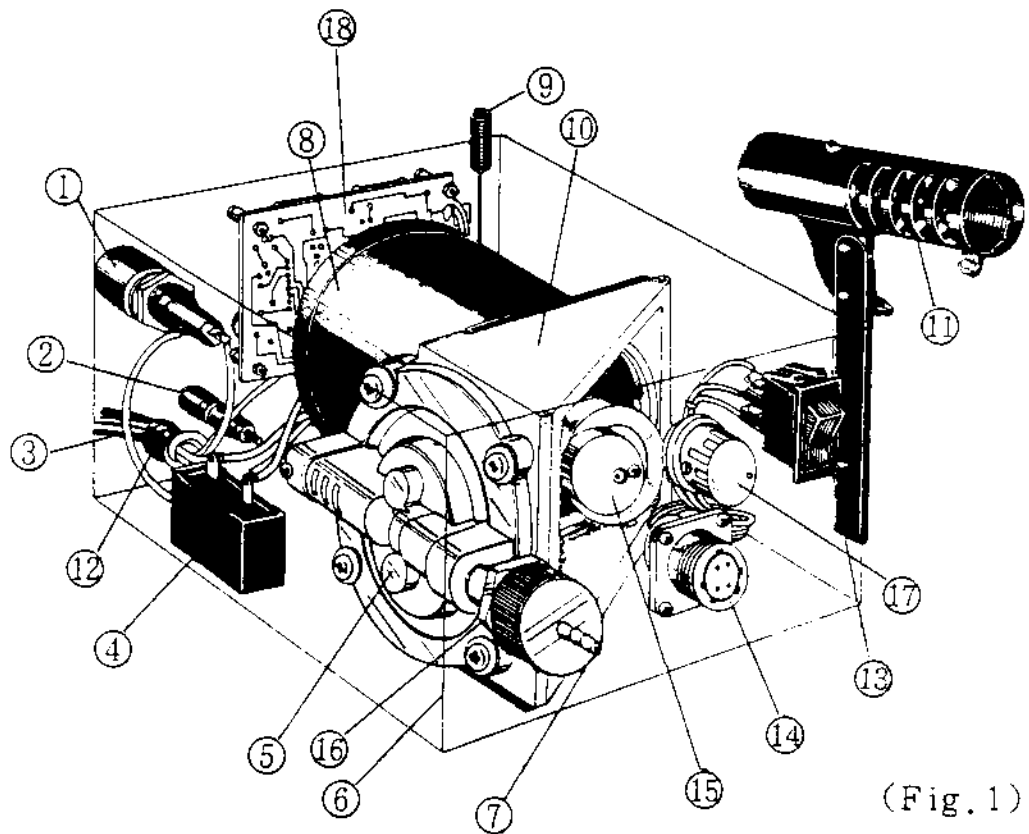

(Fig. 1)

- |                                       |                           |
|---------------------------------------|---------------------------|
| 1. Fuse Holder                        | 2. Ground Terminal        |
| 3. Power Supply Cord Set              | 4. Capacitor              |
| 5. Pump Head                          | 6. Case                   |
| 7. Vacuum Outlet Cap                  | 8. Electric Motor         |
| 9. Nozzle Cleaning Pin                | 10. Pump Body             |
| 11. Iron Stand                        | 12. Strain Relief Bushing |
| 13. Illuminated Power Switch          | 15. Balance Weight        |
| 14. Iron Connector Socket             | 17. Heat Control Dial     |
| 16. Vacuum Outlet Retainer            |                           |
| 18. Heat Control Printed Wiring Board |                           |

b) Desoldering Iron

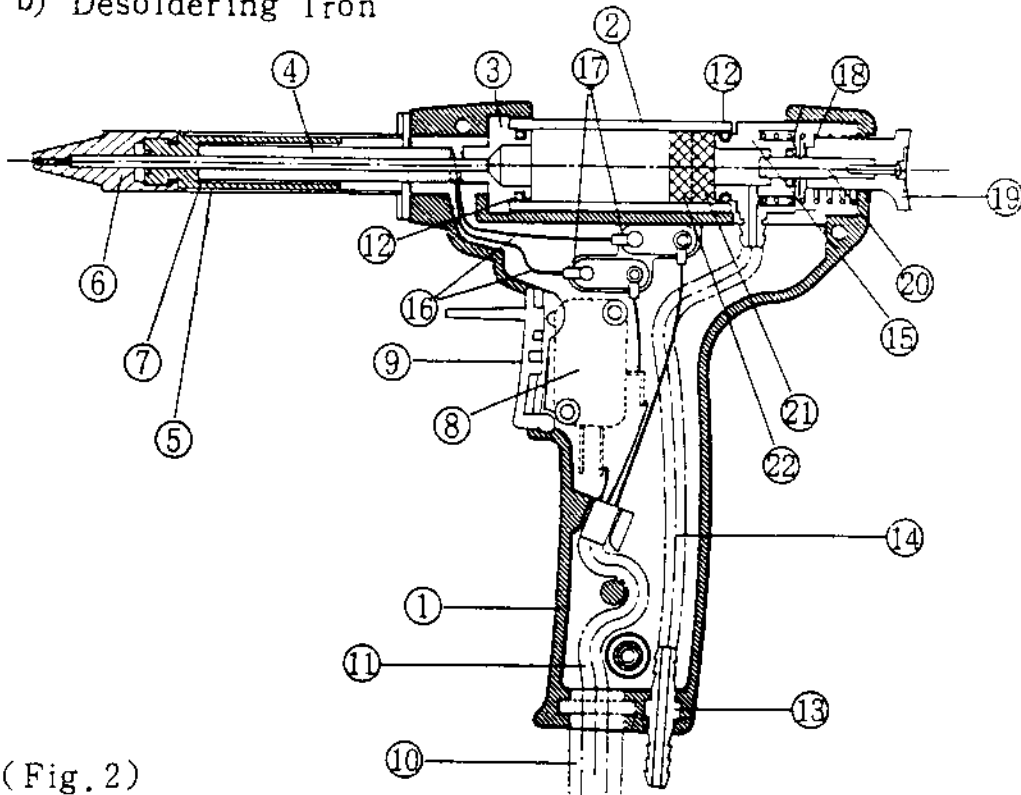

(Fig. 2)

- |                         |                              |
|-------------------------|------------------------------|
| 1. Housing (Handle)     | 2. Filter Pipe               |
| 3. Front Holder         | 4. Heating Element           |
| 5. Element Cover        | 6. Nozzle                    |
| 7. Heating Core         | 8. Micro - switch            |
| 9. Trigger              | 10. Cord Protective Covering |
| 11. 4-wired Supply Cord | 12. O - Ring                 |
| 13. Hose Joint          | 14. Guide Hose               |
| 15. Back Holder         | 16. Element Lead Line        |
| 17. Crimped Connector   | 18. Holder Spring            |
| 19. Knob                | 20. Holder Fitting           |
| 21. Felt Filter (white) | 22. Steel Wool Filter        |

### 3. Setting Up No. 483

1. Remove two screws on the side of case and assemble Iron stand as per Fig. 3.
2. The nozzle hole of unused new nozzle is stopped by pre-tinning, but it will open when iron is heated and vacuum pump is moved. (Fig. 3)
3. Remove a packing cover on vacuum outlet retainer (not shown). Screw on vacuum outlet cap (Fig. 4, Item 4) with white felt filter (Fig. 4, Item 3) to vacuum outlet retainer (Fig. 4, Item 2).

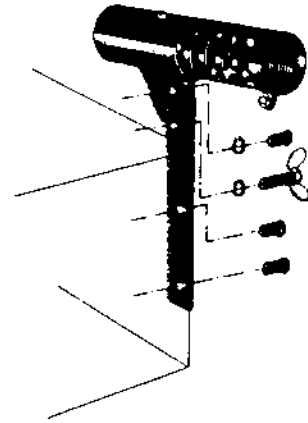

### 4. Operating Procedures

1. Connect the desoldering iron connector plug to the iron connector (Fig. 1, Item 14) and the suction hose line to the vacuum outlet cap (Fig. 1, Item 7). Place the desoldering iron into the iron stand (Fig. 1, Item 11) and adjust the angle of the stand.
2. Plug the power cord (Fig. 1, Item 3) into the power supply.
3. Adjust the nozzle temperature by means of the heat control dial (Fig. 1, Item 17).

Temperature control dial

Low - approx. 300°C ( 572°F )

Mid - approx. 350°C ( 662°F )

High- approx. 400°C ( 752°F )

4. Turn the power switch on. Make sure that the power switch light is on, and wait for approx. 10 minutes for the desoldering iron to heat up.

Caution : Never attempt to use the iron before it has sufficiently heated up as the hole in the nozzle or the inside of the heating core may become clogged with cold solder and flux.

Clean the nozzle with the provided nozzle pin (small pin). Remove the nozzle from the soldering iron and clean the heating core with the provided heating core cleaning pin (large pin).

5. After 10 minutes, insert the supplied nozzle cleaning pin into the hole in the nozzle in order to remove any material that may be clogging the nozzle or the heating core.
6. Place the nozzle on the lead of the component to be removed and gently move the iron back and forth for 2 or 3 seconds. When the lead begins to move freely, the solder is sufficiently melted. Pull the desoldering iron trigger, and the vacuum pump will absorb the melted solder.

Note : If the solder is not sufficiently melted, the component will not be properly desoldered due to insufficient suction.



Should this occur, resolder the component and repeat the desoldering process from step 5 above.

## RECOMENDED DAILY MAINTENANCE

Cleaning Procedure of Nozzle & Heating Core.

\*Turn unit on, and allow the unit to warm up.

(Approx 10 minutes)

1. Clean the Nozzle after every 150-200 desoldering operations with the Cleaning Wrench or Small Cleaning Pin.
2. Clean the Heating Core after every 800-1000 desoldering operations with the Large Cleaning Pin.

## Heating Core Cleaning Procedure

1. Turn the Nozzle counterclockwise with Cleaning Wrench and remove it.
2. Insert the Large Cleaning Pin and turn the pin several times.
3. After making sure that the Cleaning Pin can pass through smoothly, apply anti-seize on the threads of the Nozzle and the Heating Core.
4. Insert the Small Cleaning Pin and clean the Nozzle again.

# Desoldering Iron may be clogged with solder, flux etc, ..... and that can cause a decrease of the suction power. So, we recomend you above Daily Maintenance.

## 5. Maintenance

### A) Replacement of the Filters in the Desoldering Iron

Should the suction power of the desoldering iron become reduced due to the accumulated solder in the filter pipe (Fig. 2, Item 2), replace the steel wool and felt filters (Fig. 2, Item 21 & 22) in the following manner.

1. Pull the knob (Fig. 2, Item 19) at the back of the desoldering iron out and turn it approx.  $90^\circ$  to either the left or right.
2. Remove the filter pipe (Fig. 2, Item 2) from the desoldering iron by sliding it out approx. 5 mm (0.2 in) and lifting it up and out.

Caution : 1. If the filter pipe is hot, turn the power switch off and wait until the pipe has cooled, or wear a glove while handling it.

2. Do not drop the filter pipe. It is made of Pyrex glass and is very fragile.

3. Remove the accumulated solder from the filter pipe. If necessary, replace the steel wool

and felt filters. The felt filter should be replaced whenever it has become colored or hardened with flux.

Caution : Never attempt to use the desoldering iron without the filters in place as the vacuum pump may become damaged.

Note : Be sure to insert the filters so that the felt filter (Fig.2. Item 21) is at the back and the steel wool filter (Fig.2. Item 22) is at the front of it.

#### B) Replacement of the Vacuum Outlet Retainer Filter

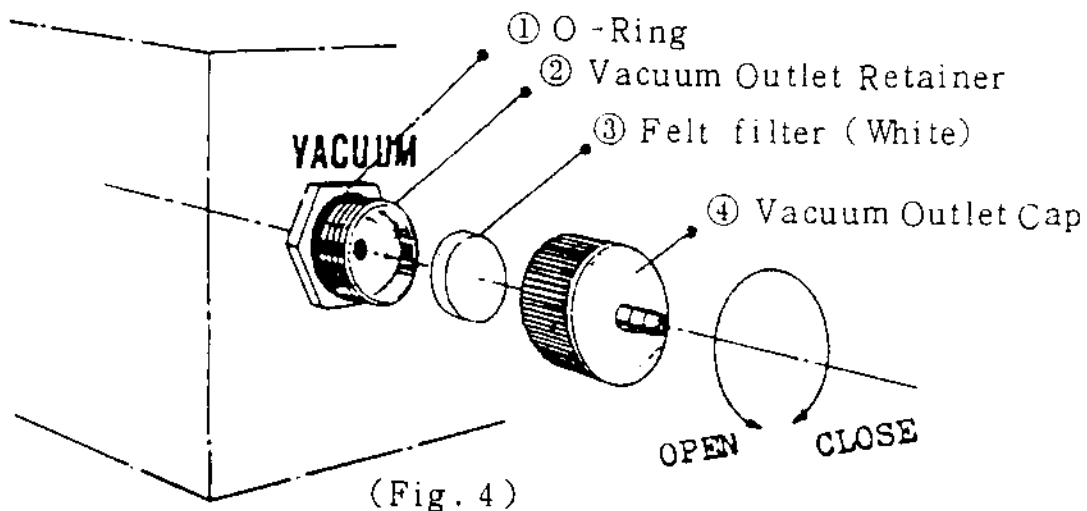

Should the suction power remain weak after replacing the filters, the felt filter in the vacuum outlet retainer (Fig.4, Item 2) must be replaced. This should be done as follows.

1. Turn the vacuum outlet cap (Fig.4, Item4) to the left and remove it.
2. Replace the white felt filter (Fig.4, Item3) that is inside the vacuum outlet retainer (Fig.4, Item2).

Note: The felt filter in the vacuum outlet retainer is the same one used in the filter pipe.

### C) Replacement of the Nozzle

1. Use a pliers to unscrew (counterclockwise) the nozzle (Fig.5, Item6).
2. Coat the threads of the new nozzle with the supplied anti-seizing lubricant and screw the nozzle onto the desoldering iron.

Note: 1. The nozzle should be replaced while the desoldering iron is hot as solder may be binding the nozzle to the heating core (Fig. 5, Item7).

2. Be careful not to overtighten the new nozzle as you may strip the threads.
3. At the end of each day of use, loosen the nozzle to prevent it from "freezing" (seizing).

# Desoldering Iron Construction Sketch

(Fig. 5)

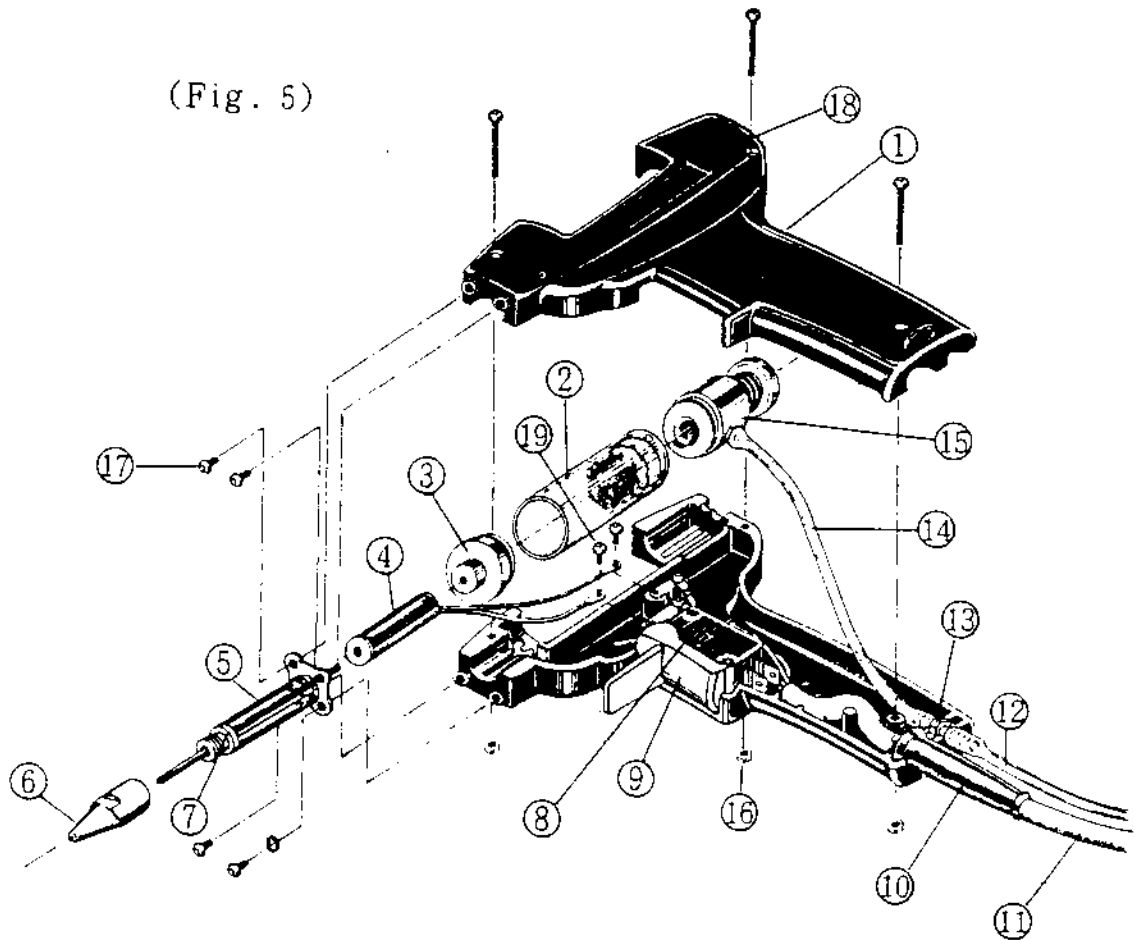

- |                             |                              |
|-----------------------------|------------------------------|
| 1. Housing (Handle )        | 2. Filter Pipe               |
| 3. Front Holder             | 4. Heating Element           |
| 5. Element Cover            | 6. Nozzle                    |
| 7. Heating Core             | 8. Micro-switch              |
| 9. Trigger                  | 10. Cord Protective Covering |
| 11. 4 - wired Supply Cord   | 12. Hose                     |
| 13. Hose Joint              | 14. Guide Hose               |
| 15. Back Holder             | 16. Housing Nut              |
| 17. Flange Set Screw        | 18. Housing Set Screw        |
| 19. Element Connection Nuts |                              |

#### D) Replacement of the Heating Element

Should the heating element break, replace it in the following manner.

1. Remove the filter pipe (Fig. 5, Item 2) by referring to steps 1 and 2 of the filter replacement procedure (A).
2. Remove the flange set screws (Fig. 5, Item 17).
3. Remove the housing set screws (Fig. 5, Item 18) and carefully lift off the housing (Fig. 5, Item 1).
4. Unscrew the heating element connection nuts (Fig. 5, Item 19).
5. Remove the front holder (Fig. 5, Item 3).
6. Replace the heating element (Fig. 5, Item 4).
7. Reassemble the desoldering iron by following the disassembly steps in reverse order.

#### \*\*\* After Replacement of the Heating Element \*\*\*

1. Loosen the fastener marked "CAL" on the back side of the pump unit.
2. Using a "minus" (-) screwdriver, turn the temperature control potentiometer to Low (fully counterclockwise). After connecting the unit to the power supply, allow it to sit for 10 Minutes.
3. Turn the temperature control potentiometer clockwise until the temperature of the desoldering iron tip reaches a stable 300 degree centigrade.

E) Replacement of the Heating Core Assembly and Element Cover

1. Remove the filter pipe (Fig. 5, Item 2) by referring to steps 1 and 2 of the filter replacement procedure (A).
2. Remove the nozzle (Fig. 5, Item 6) by referring to step 1 of the nozzle replacement procedure (C).
3. Remove the 4 flange set screws (Fig. 5, Item 17).
4. Remove the front holder (Fig. 5, Item 3).
5. Remove the element cover (Fig. 5, Item 5), then remove the heating core (Fig. 5, Item 7) by gently pulling it off.
6. Replace the element cover and the heating core assembly.
7. Insert the small stainless steel pipe of the heating core assembly into the hole in the front holder.
8. Reassemble the desoldering iron by following the disassembly steps in reverse order.
9. Reattach the grounding wire and the element cover flange with the 4 flange set screws.

F) Cleaning and Replacement of the Vacuum Pump Diaphragm and Valve

Even though the HAKKO Ace No. 483 desoldering tool incorporates a 3-ply filter structure, flux may still occasionally cling to the diaphragm or valve plate, causing the vacuum suction power to drop after several days of useage. To clean or replace the vacuum pump diaphragm and valve, follow the procedure outlined below.

1. Disconnect the power cord (Fig. 1, Item 3) from the power supply.
2. Unscrew the vacuum outlet retainer (Fig. 4, Item 2) and remove it.
3. Unscrew the 2 screws that secure the desoldering iron stand to the unit and remove the stand.
4. Unscrew the screws that secure the case to the unit and remove the case.
5. Remove the pump head (Fig. 6, Item 1).
6. Unscrew and remove the diaphragm adjustment plate (Fig. 6, Item 2) and the diaphragm (Fig. 6, Item 3).
7. Unscrew and remove the fixing plate (Fig. 7, Item 5) from inside the pump head (Fig. 7, Item 1), and remove the valve plate (Fig. 7, Item 4).



8. Clean off any flux that is adhering to the valve plate and the diaphragm with alcohol, etc. If any of the pump parts are cracked or deformed, replace them with new parts.
9. Reassemble the unit by following the disassembly steps in reverse order.

Note: 1. Be sure to reassemble the fixing plate (Fig. 7, Item 5) in the proper direction, i. e., so that the countersink in the fixing plate is opposite the counterbored holes in the pump head (Fig. 7, Item 1).

### Construction of Diaphragm

(Fig. 6)

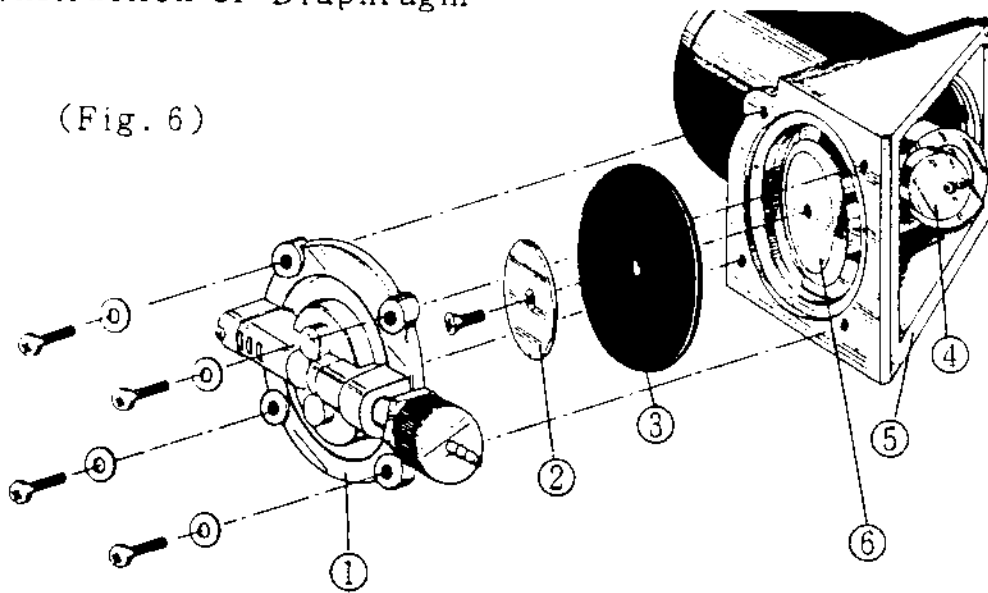

- |              |                               |
|--------------|-------------------------------|
| 1. Pump Head | 2. Diaphragm Adjustment Plate |
| 3. Diaphragm | 4. Balance Weight             |
| 5. Pump Body | 6. Crank Arm                  |

## Pump Head Construction Sketch

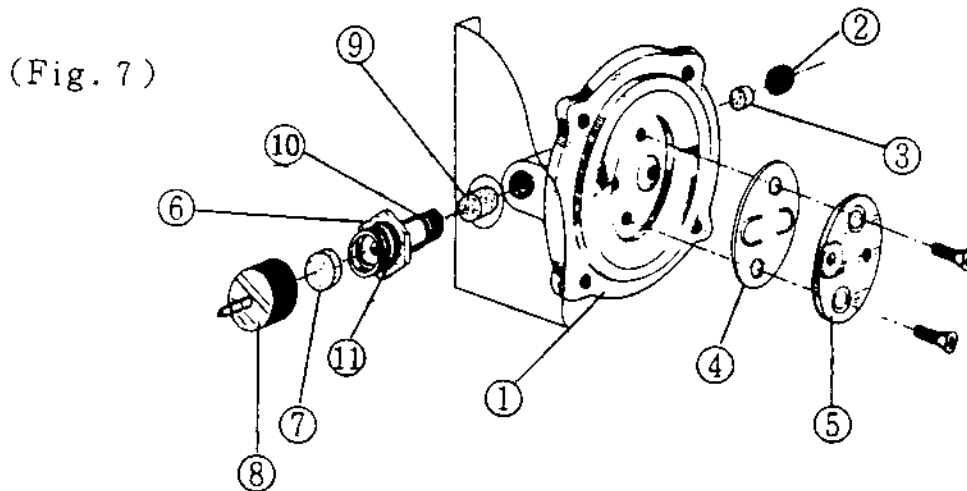

- |   |                        |
|---|------------------------|
| 1. Pump Head  | 2. Filter Holding Plug |
| 3. Exhaust Filter   | 4. Valve Plate         |
| 5. Fixing Plate (Pay special attention not to make an error of the direction when attaching.) |                        |
| 6. Vacuum Outlet Retainer   | 7. Felt Filter         |
| 8. Vacuum Outlet Cap  | 9. Air Inlet Filter    |
| 10. O-Ring P - 9  | 11. O-Ring P - 18      |

2. Make sure that the crank arm (Fig. 6, Item 6) is at the lowest point before replacing the diaphragm (Fig. 6, Item 3), the diaphragm setting plate (Fig. 6, Item 2) and the pump head (Fig. 6, Item 1).
3. Apply a little silicon oil to the surfaces of the valve plate (Fig. 7, Item 4) and the diaphragm (Fig. 6, Item 3) before reassembling

them. This will make future disassembly much easier.

4. Be careful not to allow any dust or other foreign matter to enter the pump during reassembly.

## 6. Trouble shooting Guide

<u>Problem</u>	<u>Points to Check</u>
Power switch lamp does not light up.	<ol style="list-style-type: none"><li>1. Is the power cord plugged in?</li><li>2. Is the fuse blown?</li></ol>
Vacuum pump does not operate.	<ol style="list-style-type: none"><li>1. Is the desoldering iron properly connected?</li></ol>
Solder is not absorbed.	<ol style="list-style-type: none"><li>1. Is the vacuum pump working?</li><li>2. Is the hose properly connected?</li><li>3. Is the nozzle hot enough?</li><li>4. Is the filter pipe full of accumulated solder?</li><li>5. Are the felt filter hardened or discolored with flux?</li><li>6. Is there a vacuum leak between the filter pipe and either the front or back holder?</li><li>7. Is there a vacuum leak between the vacuum outlet retainer and the vacuum outlet cap?</li><li>8. Is the nozzle or the hole in the heating core clogged with solder?</li></ol>

The solder is not thoroughly melted.

1. Is the desoldering iron properly connected ?
2. Is the heating element broken ?  
(If so, the nozzle will not be warm at all.)
3. Is the nozzle properly tightened ?
4. Is the 4-lead cord broken ?
5. Is the nozzle oxidized or become contaminated with flux ?

\* Should problems still exist, please contact us directly or through our sales agent.

## 7. Wiring Diagram

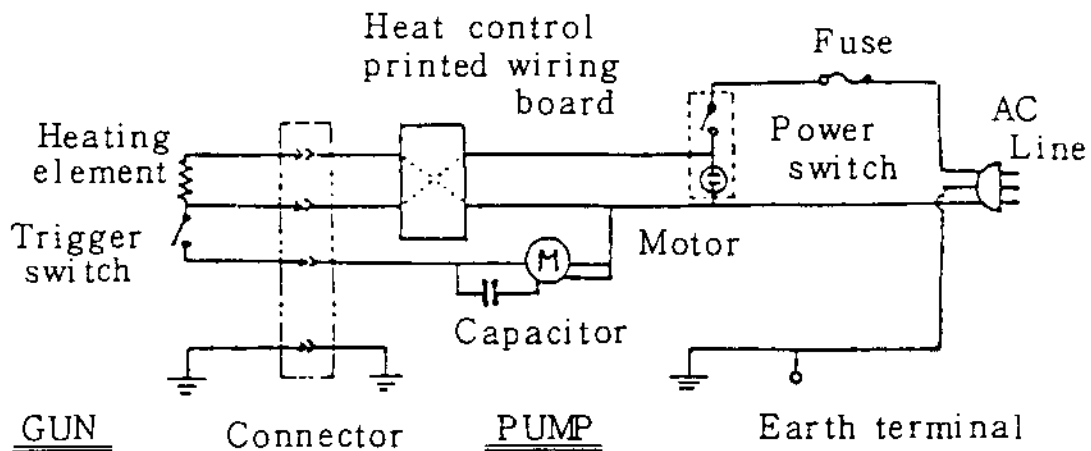

## 8. Replacement Parts

Part No.	Part Name	Specifications															
<del>2483-1</del> 483-T-( )	Nozzle 0.8 φ 1.0 φ 1.3 φ 1.6 φ	 <table border="1" style="float: right;"> <tr> <td></td> <td>0.8 φ</td> <td>1.0 φ</td> <td>1.3 φ</td> <td>1.6 φ</td> </tr> <tr> <td>A</td> <td>0.8</td> <td>1.0</td> <td>1.3</td> <td>1.6</td> </tr> <tr> <td>B</td> <td>2.5</td> <td>2.5</td> <td>3.0</td> <td>3.0</td> </tr> </table>		0.8 φ	1.0 φ	1.3 φ	1.6 φ	A	0.8	1.0	1.3	1.6	B	2.5	2.5	3.0	3.0
	0.8 φ	1.0 φ	1.3 φ	1.6 φ													
A	0.8	1.0	1.3	1.6													
B	2.5	2.5	3.0	3.0													
481-021	<del>4481-11</del> Filter Set	One steel wool & one felt															
481-002	<del>4481-12</del> Filter Pipe	with Filter set															
483-H-V12	<del>3483-1</del> Heating Element																
483-012	<del>3483-11</del> Heating Core	with Element cover															
481-101	<del>481-01</del> Front Holder	with O-Ring															
481-102	<del>481-02</del> Back Holder	Assembly															
A1012	<del>481-03</del> O - Ring	P - 12 ( Set of 5 )															
481-201	<del>481-04</del> Diaphragm Set	Valve plate, Diaphragm and Sponge filters.															
	<del>481-05</del> Small Cleaning Pin (for Nozzle & Heating core)	B1086, B1087, B1088, B1089															
B1085	<del>481-051</del> Heating Core Cleaning Pin	(large)															
700-112	<del>481-06</del> Housing																
N/A	<del>481-07</del> 4-Wired Cord	without Connector Plug															
483-020	<del>707-09</del> Nozzle Cleaning Wrench																

888-001

Heavy Duty Cleaning Pin for Heating Core



**HAKKO**

**HAKKO METAL INDUSTRIES, LTD.**

**HEAD OFFICE**

4-5, SHIOKUSA 2-CHOME, NANIWA-KU, OSAKA,  
556 JAPAN TEL: (06)561-3225 FAX (06)568-0821  
TELEX: HAKKOOSA J65274

**TOKYO OFFICE**

85, KANDA SAKUMA-KASHI CHIYODA-KU, TOKYO,  
101 JAPAN TEL: (03)866-1161

**U.S. Affiliate AMERICAN HAKKO PRODUCTS, INC.**

3086 NORTH LIMA ST., BURBANK, CALIFORNIA 91504  
TEL: (818)848-1515 FAX: (818)848-2887